

Inductive proximity sensor

- M8 stainless steel housing
- 2m cable
- NPN / normally open

Item code	INO-0015-ADF / 3	Circuit protection	surge, overload, reverse polarity protection
Sensing distance	1.5 mm	Indicator	yellow LED
Mounting	flushed	Ambient temperature	-25 ... 70 °C
Output	NPN NO	Ambient moisture	35 ... 95 % RH
Supply voltage	10 ... 30 VDC	Switch frequency	2000 Hz
Standard target	Fe 8*8*1t	Voltage resistant	1000 V / AC 50 / 60 Hz 60 s
Switch shifts	≤ ± 10 %	Insulation resistant	≥ 50 MΩ (500 VDC)
Hysteresis	1 ... 20 %	Vibration withstand	repeated amplitude 1.5 mm 10 ... 50 Hz (2 hours each for X, Y, Z direction)
Repeated error	≤ 3 %	Protection	IP 67
Load current	≤ 150 mA	Housing material	stainless steel
Residual	≤ 2.5 VDC	Connection	2 m cable
Current consumption	≤ 10 mA		

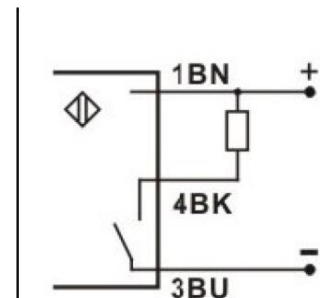
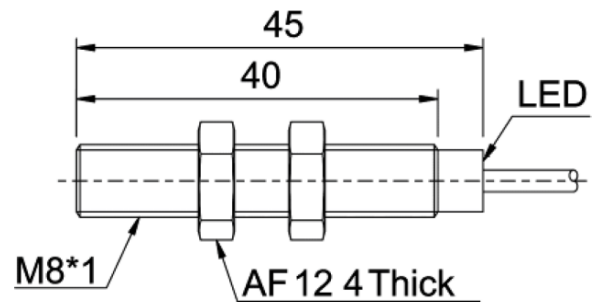
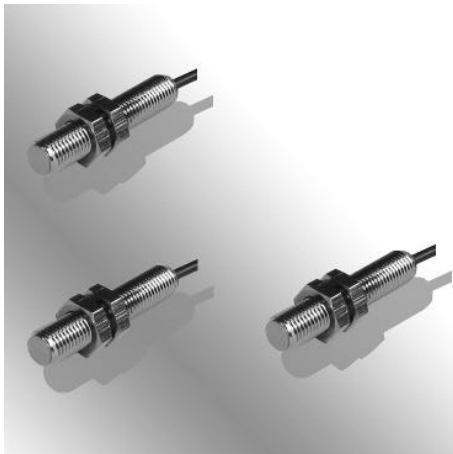

BN:+ BK: out BU: -